

# INSTRUCTION MANUAL

## EB-270DSA Swivel Head Metal Cutting Band Saw (415V) 260 x 100mm (W x H) Rectangle

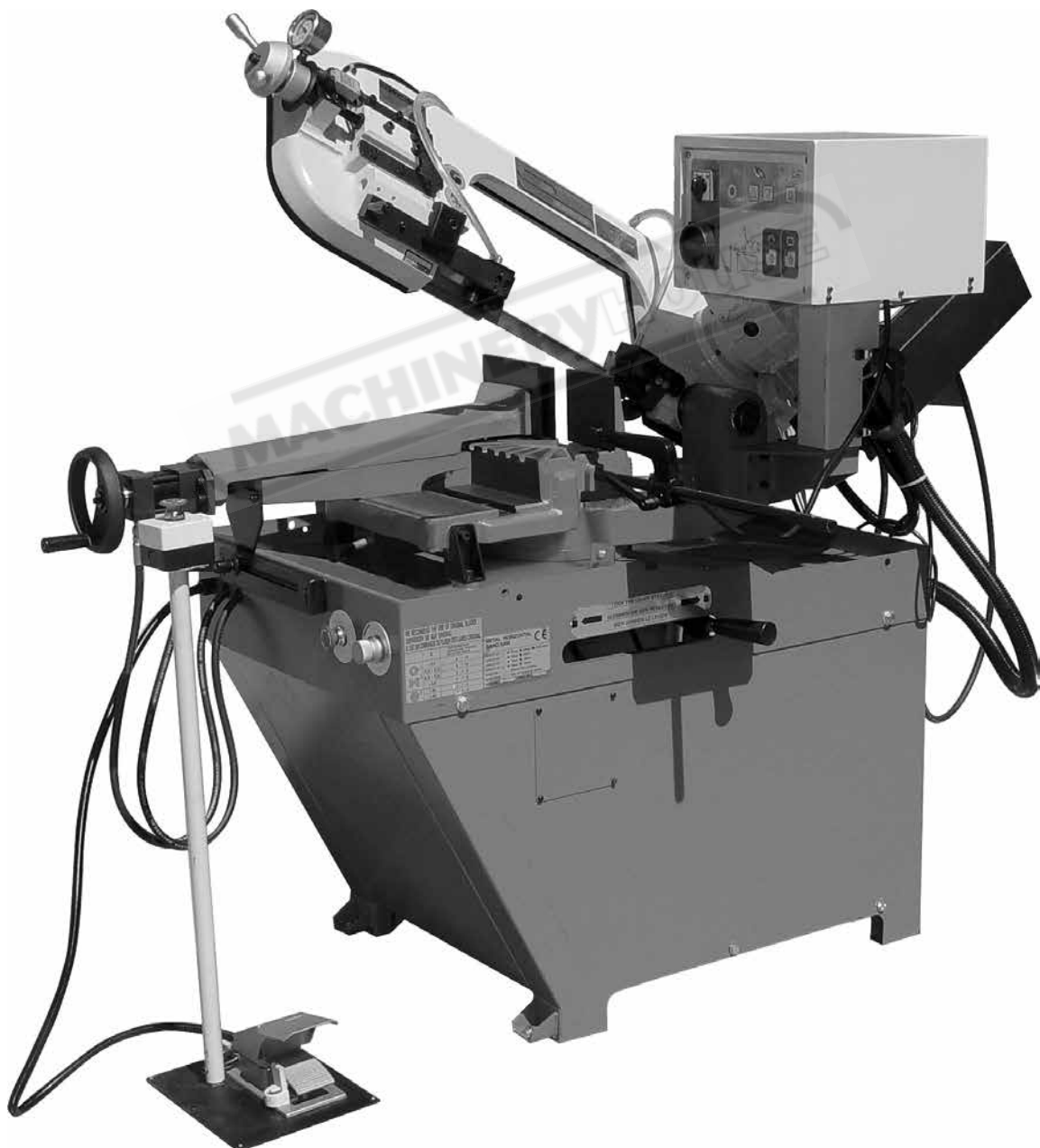

**B066**

## Contents

### Chapter 1

#### ACCIDENT PREVENTION AND SAFETY REGULATION

1.1 Advice for the operator.....	2
1.2 The electrical equipment according to European Standard" CENELEC EN 60 204-1" (1992).....	2
1.3 Emergencies according to European Standard "CENELEC EN 60 204-1 (1992)".....	2

### Chapter 2

#### MACHINE DIMENSIONS TRANSPORT INSTALLATION DISMANTLING

2.1 Machine dimensions.....	2
2.2 Assembling the control box to the saw.....	2
2.3 Machine Transportation.....	3
2.4 Minimum requirements for housing the machine.....	3
2.5 Anchoring the machine.....	3
2.6 Instructions for assembly of the loose parts and accessories.....	3
2.7 Deactivation of machine.....	3
2.8 Dismantling.....	3

### Chapter 3

#### THE MACHINE'S FUNCTIONAL PARTS

3.1 The saw arm.....	3
3.2 Controls.....	4
3.3 Vise adjustment.....	4
3.4 Cutting angle adjustment.....	5
3.5 The base.....	5
3.6 The operation cycle.....	5

### Chapter 4

#### ADVICE ON USING YOUR BANDSAW

4.1 Recommendations and advice for using the machine.....	6
---	---

### Chapter 5

#### ADJUSTING YOUR MACHINE

5.1 Blade tension assembly.....	7
5.2 Adjusting the blade guide.....	7
5.3 Saw frame return stroke-limiting device.....	7
5.4 Changing the blade.....	8
5.5 Adjusting the blade to the flywheels.....	8
5.6 Replacing saw frame return spring.....	8

### Chapter 6

#### ROUTINE AND SPECIAL MAINTENANCE

6.1 Daily maintenance.....	9
6.2 Weekly maintenance.....	9
6.3 Monthly maintenance.....	9
6.4 Six-monthly maintenance.....	9
6.5 Maintenance of other machine parts.....	9
6.6 Oils for lubricating coolant.....	9
6.7 Oil disposal.....	9
6.8 The gear box.....	9
6.9 Special maintenance.....	9

### Chapter 7

#### TECHNICAL CHARACTERISTICS

7.1 Table of cutting capacity and technical details.....	9
--	---

### Chapter 8

#### MATERIAL CLASSIFICATION AND CHOICE OF TOOL

8.1 Definition of materials.....	10
8.2 Selecting blade.....	10
8.3 Teeth pitch.....	10
8.4 Cutting and advance speed.....	11
8.5 Blade running-in.....	11
8.6 Blade structure.....	11
8.7 Blade type.....	11

### Chapter 9

#### NOISE TESTS

.....	12
-------	----

### Chapter 10

#### WIRING DIAGRAM

.....	13
-------	----

### Chapter 11

#### TROUBLESHOOTING

11.1 - Electrical components diagnosis.....	15
11.2 - Blade and cut diagnosis.....	17

### Chapter 12

#### MACHINE COMPONENTS

12.1 Parts list.....	21
12.2 Explosion drawings.....	24

## 1 ACCIDENT PREVENTION AND SAFETY REGULATION

This machine has been designed to comply with national and community accident-prevention regulations. Improper use and/or tampering with the safety devices will relieve the manufacturer of all responsibility.

### 1.1 Advice for the operator

- Check that the voltage indicated on machine motor is the same as the line voltage.
- Check the efficiency of your electric supply and grounding system; connect the power cable of the machine to the socket and the ground lead (yellow-green in color) to the grounding system.
- When the saw frame is in suspended mode (or raised) the blade must not move.
- Only the blade section used for cutting must be kept unprotected. To remove guards operate on the adjustable head.
- It is forbidden to use the machine without its shields
- Always disconnect the machine from the power socket before blade change or carrying out any maintenance job, even in the case of abnormal machine operation.
- Always wear suitable eye protection.
- Never put your hands or arms into the cutting area while the machine is operating.
- Do not shift the machine while it is cutting.
- Do not wear loose clothing like: shirts with sleeves that are too long, gloves that are too big, bracelets, chains or any other object that could get caught in the machine during operation. Tie back long hair.
- Keep the area free of equipment, tools, or any other object.
- Perform only one operation at a time. Never have several objects in your hands at the same time. Keep your hands as clean as possible.
- All internal operations, maintenance or repairs, must be performed in a well-lit area or where there is sufficient light from extra sources so as to avoid the risk of even slight accidents

### 1.2 The electrical equipment according to European Standard "CENELEC EN 60 204-1" which assimilates, with some integrating modifications, the publication "IEC 204-1 (1992)"

- The electrical equipment ensures protection against electric shock as a result of direct or indirect contact. The active parts of this equipment are housed in a box to which access is limited by screws that can only be removed with a special tool; the parts are fed with alternating current as low voltage (24V). The equipment is protected against splashes of water and dust.
- Protection of the system against short circuits is ensured by means of rapid fuses and grounding; in the event of a motor overload, protection is provided by a thermal probe.
- In the event of a power cut, the specific start-up button must be reset.
- The machine has been tested in conformity with point 20 of EN 60204

### 1.3 Emergencies according to European Standard "CENELEC EN 60 204-1 (1992)"

- In the event of incorrect operation or of danger conditions, the machine may be stopped immediately by pressing the red mushroom button.
  - The casual or voluntary removal of the blade cover of the flywheels causes the stepping-in of a interlock switch that automatically stops all machine functions.
  - In case blade breakage, the tension release microswitch disconnects all machine functions.
- NOTE: Resetting of machine operation after each emergency stop requires specific restart button.

## 2 MACHINE DIMENSIONS TRANSPORT INSTALLATION DISMANTLING

### 2.1 Machine dimensions

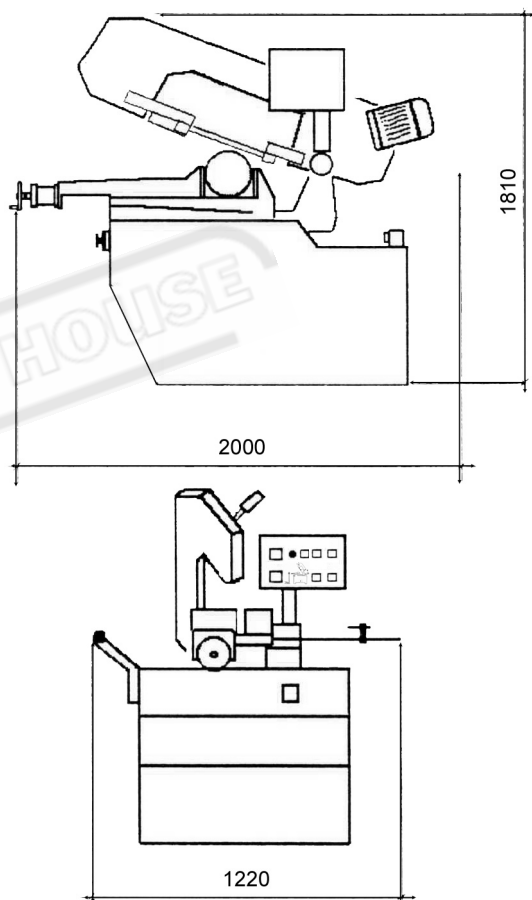

### 2.2 Assembling the control box to the saw

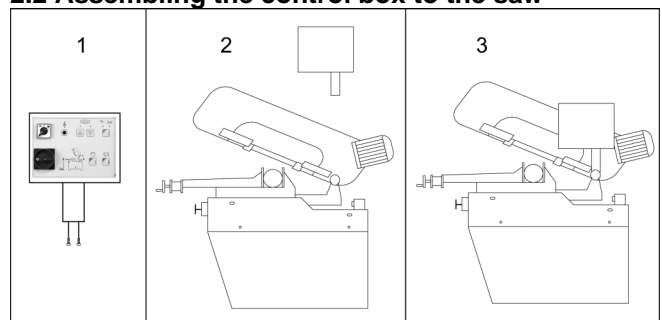

- Attach the control box to the saw with two provided set screws.

### 2.3 Machine Transportation

If the machine needs to be moved in its own packing, use a forklift truck or sling it with straps as illustrated.

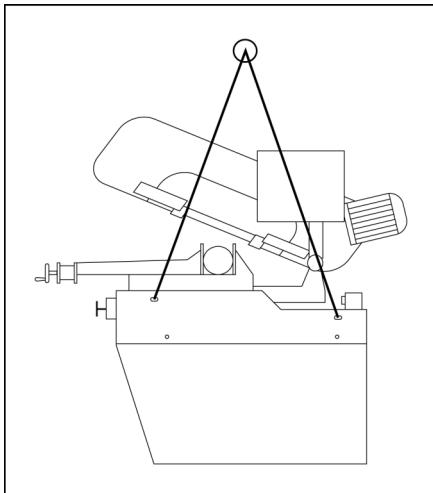

### 2.4 Minimum requirements for housing the machine

- Main voltage and frequency must comply with the machine's motor requirements.
- Environment temperature should fall within  $-10\text{ }^{\circ}\text{C}$  to  $+50\text{ }^{\circ}\text{C}$ .
- Relative humidity cannot be over 90%.

### 2.5 Anchoring the machine

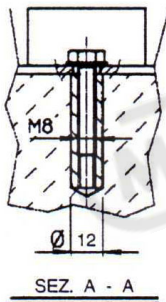

Position the machine on a firm cement floor, maintaining, at the rear, a minimum distance of 800 mm from the wall; anchor it to the ground as shown in the diagram, using screws and expansion plugs or tie rods sunk in cement, ensuring that it is sitting level.

### 2.6 Instructions for assembly of the loose parts and accessories

Fit the components supplied:

Detail 1 Mount bar-stop rod

Detail 2 Mount and align the roll-supporting arm as per the counter-vice table.

### 2.7 Deactivation of machine

- If the sawing machine is to be out of use for a long period, it is advisable to proceed as follows:

- 1) Detach the plug from the electric supply panel
- 2) Loosen blade
- 3) Release the arch return spring
- 4) Empty the coolant tank
- 5) Carefully clean and grease the machine
- 6) If necessary, cover the machine.

### 2.8 Dismantling (due to deterioration and/or obsolescence)

#### General rules

If the machine is to be permanently demolished and/or scrapped, divide the material to be disposed of according to type and composition, as follows:

- 1) Cast iron or ferrous materials, composed of metal alone, are secondary raw materials, so they may be taken to an iron foundry for re-smelting after having removed the contents (classified in point 3).
- 2) Electrical components, including the cable and electronic material (magnetic cards, etc.), fall within the category of material classified as being assimilated to urban waste according to the laws of your local, state, or federal government, so they may be set aside for collection by the public waste disposal service;
- 3) Old mineral and synthetic and/or mixed oils, emulsified oils and greases are considered hazardous or special refuse, so they must be collected, transported and disposed of at a special waste disposal service.

NOTE: The standards and legislation concerning refuse is in a constant state of evolution, therefore is subject to changes. The user must keep informed of the regulations at the time of disposal as these may differ from those described above.

## 3 THE MACHINE'S FUNCTIONAL PARTS

### 3.1 The saw arm

Machine part consisting of drive members (gear motor or variable speed motor, flywheels), tension and guides (blade guide slide, blade guide blocks) of blade.

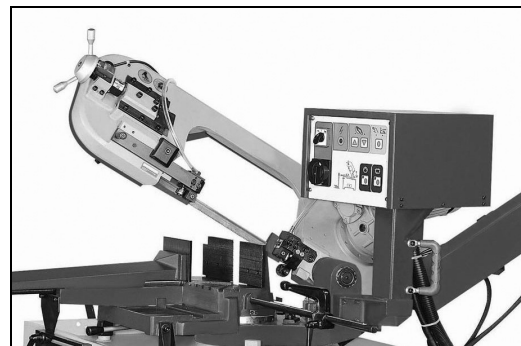

### 3.2 Controls

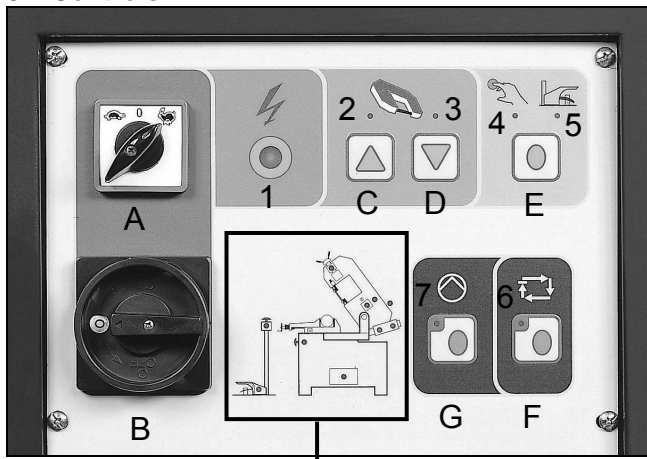

1. Power supply ON, indicator lights
2. Saw bow up, indicator light
3. Saw bow down, indicator light
4. Hand operation, indicator light
5. Foot pedal operation, indicator light
6. Cycle start switch indicator light
7. Start switch (hydraulic flow control), indicator light
8. Saw bow maximum height, indicator light
9. Saw bow lowest height, indicator light
10. Open blade cover, warning indicator light
11. Improper speed selection, warning indicator light
12. Motor overload, warning indicator light
13. Broken blade, warning indicator light
14. Emergency button indicator light
15. Hydraulic motor overload, warning indicator light
16. Foot pad's emergency button indicator light
17. Foot pad, operation indicator light

### 3.3 Vise adjustment

#### Clamping the Work Piece

- Place work piece between the jaws.
- Use the hand wheel to close the vise jaw. For multiple cuts of a same size material, leave a small gap between the work piece and vise jaw. Push cycle start button (F). The vise will automatically clamp the work piece while going through the operation cycle. When the operation cycle is finished, the vise will open and the work piece can be adjusted or replaced.

#### Operation of the Vise

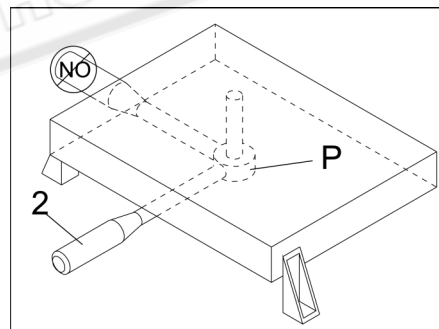
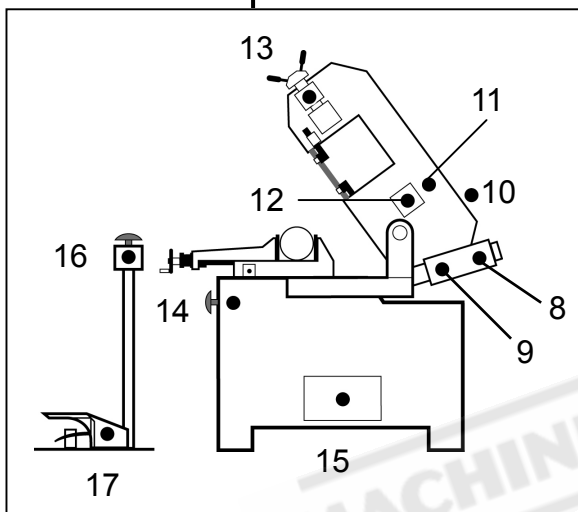

#### A~G Control Switches

- A. Speed selector
- B. Main connect switch
- C. Saw bow up switch
- D. Saw bow down switch
- E. Hand/foot pedal operation selector
- F. Cycle start switch
- G. Start switch (hydraulic flow control)
- H. Emergency button
- I. Footpad emergency button
- J. Footpad switch
- K. Flow regulator

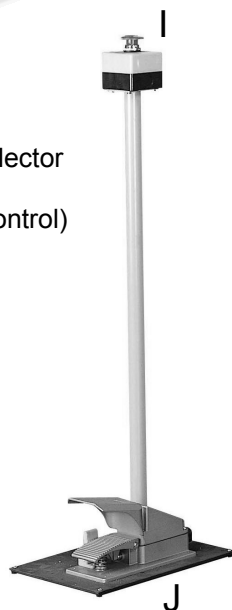

- 1~17 Indicator lights  
 Red- Warning indicator  
 Yellow- Selection indicator  
 Green- Operation indicator

When cutting angles, it may require the adjustment of the vise jaw's position so that the saw blade's path is not impeded. Follow the procedures below.

- Release the track support by turning handle (1) counter-clockwise.
- Release the vise by moving the lever (2) to the left.
- The vise may now be moved to right position or left position by pushing with one hand on the adjustable vise jaw and the other hand on the track handle (1).
- Once in position, move the lever (2) to the right to lock it into position. If the lever (2) is not between the vise/bed mounts and facing the user, then the vise will not be able to lock. If the vise lever (2) has

gone beyond or is obstructed by a vise/bed mount, then use the following procedures.

- Adjust the lever (2) by grasping at the pivot point (P) and lowering it, which may assist in the adjustment. The lever can now be freely rotated into a more convenient position. Some movement of the vise jaw may be required. Raise the lever (2) then move to the right to lock.
- Lock the track support (1) by turning handle clockwise.

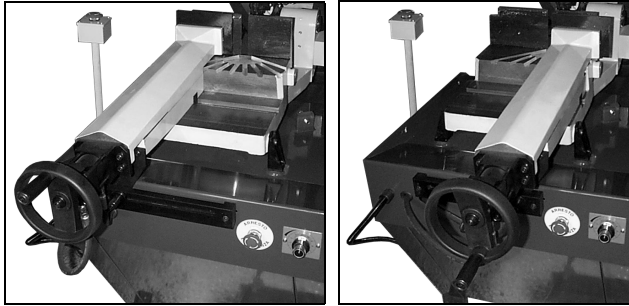

### 3.4 Cutting angle adjustment

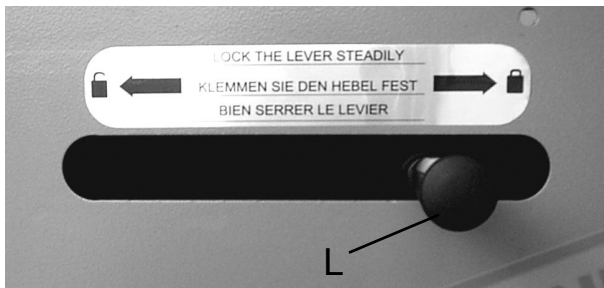

Cutting at angles

- Angle can be cut up to 60°.
- Unlock lever (L) by pushing it to the left side.
- Rotate the saw arm to the desired angle by following the index on the scale.
- Lock lever (L) by pushing to the right side.

### 3.5 The base

- A structure supporting the SAW ARM (revolving arm for gradual cutting and respective blocking system), the VISE, the BAR STOP, the ROLLER for the support of the material. The base houses the cooling liquid TANK, PUMP, and the DEVICE CONTROLLING THE AUTOMATIC HYDRAULIC LOWERING AND RISING OF THE SAW FRAME.

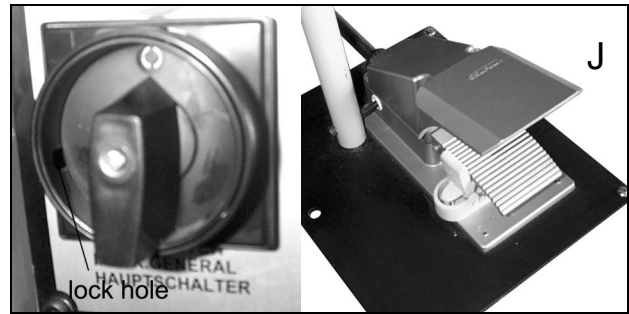
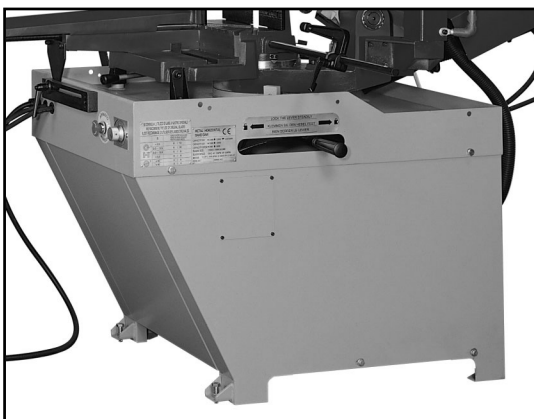

The main connect switch is designed with a lock hole. A lock can be attached to the lock hole to prevent machine operation for safety and security purposes.

- To use the footpad switch (J), first use the side of the foot to push aside the plastic clip that blocks the foot pad. Be careful not to damage the clip by using excessive force or stomping on the footpad. Next, step down on the footpad to start operation.

### 3.6 The operation cycle

- Make sure the voltage indicated on machine motor is the same as power source voltage. Connect the machine to the power source, and Press the main connect switch (B). If power indicator light (1) is on, it means the voltages are okay.
- Select the cutting speed on switch (A).
  - \*Note: While selecting the cutting speed indicator light will blink.
- Press hydraulic flow control start switch (G). \*Note: If the hydraulic flow control fails to activate, then switch (C), (D), and (F) cannot operate. Indicator light (7) will blink if any are pressed, indicating that start switch (G) has failed to activate.
- Check the hydraulic oil level. If oil rises up, it means the motor is running in the right direction. If not, rewire the plug.
- Check that the saw arm is properly set. Press saw bow switches (C) or (D) to adjust the bow height to help when setting the workpiece.
- Place the workpiece in the vise and clamp securely.
- Select the speed using speed selector switch (A). The turtle indicates low speed and the rabbit indicates high speed. "O" is for neutral.
- Be sure to stand in a safe location while operating. There are two ways to start the machine. Press the switch (C) to let the saw bow return to the highest position and then using the first method, select hand operation on selector (E) and press cycle start switch (F) to start operation. Using the second method, Select footpad operation on selector (E) and step on start footpad (J) to start operation.
- In general, start cuts by slightly turning hydraulic flow regulation switch (K) counter-clockwise from 2 to 3 to control the saw arm descent rate. If the arm descends too quickly, turn hydraulic flow regulation switch (K) clockwise all the way back to stop its descent - When cutting different material use the hydraulic flow regulation switch (K) to control saw arm's rate of descent.
  - \*Note: A saw arm dropping too quickly can cause the blade to stall on the work piece and the machine will

shut off. If so, push down on either emergency push buttons (I or H) to immediately stop all machine functions.

- During the operation cycle, the hydraulic vise will automatically close on the work piece for a distance up to 8mm. The hydraulic vise will then open maximum 8mm on end of operation. Now it is ready for the next operation. Therefore, it is not necessary to manually lock down the vise jaws on the work piece for every operation. Allowing a gap of 4-5mm between jaws and the work piece will suffice.
- The saw bow will return to the bow's maximum height upon completion of operation.

- In case of Emergency or problem during the operation cycle, press the emergency push button (H or I) down to shut off all functions.
- To release the emergency push button (H or I), rotate the mushroom shaped button clock-wise. The button will pop up and then the cutting cycle can be restarted.

- The hydraulic flow control (G) will automatically shut-off after 5 minutes of non-operation.

\*Note: If the hydraulic flow control fails to activate, then switch (C), (D), and (F) cannot operate. Indicator light (7) will blink if any are pressed, indicating that start switch (G) has failed to activate.

- If the hand operation is selected and the foot pad is used, then the hand operation indicator light (4) will blink. And vice versa, If the foot pad operation is selected and the hand switches are used, then the foot operation indicator light (5) will blink. They indicate improper selection.

- The appropriate indicator light will blink to indicate which part of the machine has gone out of order.

1. Indicator light 14 indicates the emergency button is pressed. Indicator light 16 indicates the emergency button on foot pad is pressed.
2. Indicator light 13 indicates the band saw blade has broken.
3. Indicator light 10 indicates the blade cover is open.
4. Indicator light 12 indicates the motor has overloaded.
5. Indicator light 15 indicates the hydraulic motor has overloaded.
6. Indicator light 11 indicates the speed is not properly selected.

- If the saw bow up/down switches are out of order then indicator lights 2 and 3 will blink at the same time.

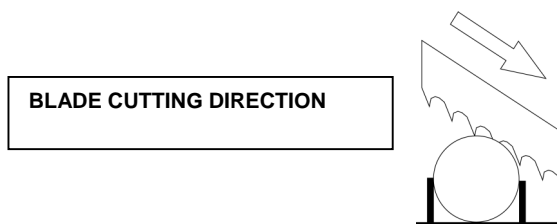

## 4 ADVICE ON USING YOUR BANDSAW

### 4.1 Recommendations and advice for using the machine

The machine has been designed to cut metal building materials, with different shapes and profiles, used in workshops, turner's shops and general mechanical structural work.

Only one operator is needed to use the machine, that must stand as shown in the picture.

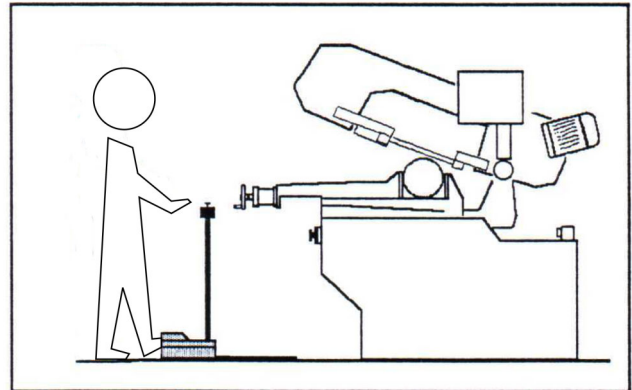

- Before starting each cutting operation, ensure that the part is firmly clamped in the vise and that the end is suitably supported.
- These figures below show examples of suitable clamping of different section bars, bearing in mind the cutting capacities of the machine in order to achieve a good efficiency and blade durability.

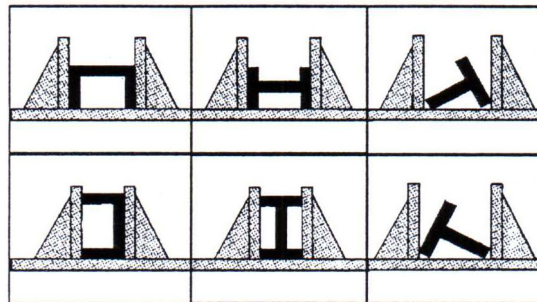

- Do not use blades of a different size from those stated in the machine specifications.
- If the blade gets stuck in the cut, press the cycle start switch or emergency button to switch off the machine. Open the vise slowly, remove the part and check that the blade or its teeth are not broken. If they are broken, change the blade.
- Check saw frame return spring to ensure proper balancing.
- Before carrying out any repairs on the machine, consult the dealer.

## 5 ADJUSTING YOUR MACHINE

### 5.1 Blade tension assembly

The ideal tension of the blade is achieved rotating the handwheel until the needle reaches the proper blade tension on the tension gauge (A).

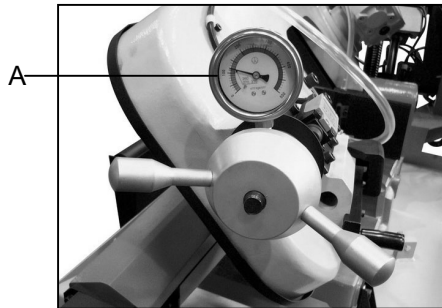

The machine will not operate if the microswitch does not actuate by contacting the touch plate (C).

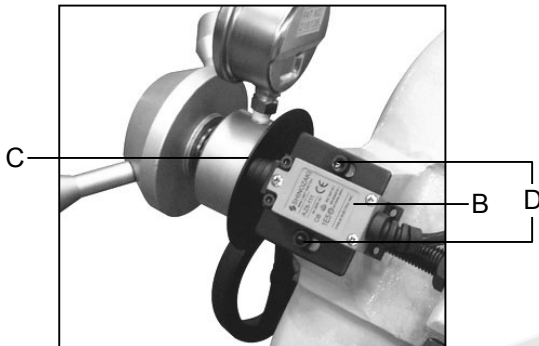

If the tension is set properly, but the microswitch (B) does not contact or trigger properly, make this adjustment.

- Loosen the setscrews (D).
- Push the microswitch (B) towards the touch plate (C). Make sure that the plunger is pressed properly.
- Tighten down the setscrews (D) to secure the microswitch (B) in place.

### 5.2 Adjusting the blade guide

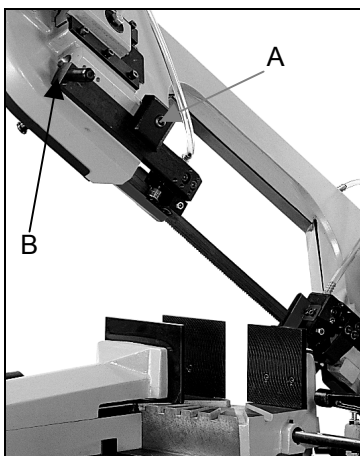

- Disconnect the machine from the power source.
- Use a Hex. Wrench to loosen Hex. Socket screw (A) on the square lock plate.
- Hold the handle (B) and slide blade guide block as

close as possible to the material without interfering with the cut

- Tighten the hex. socket screw (A).
- Reconnect the machine to power source.

### Blade guide blocks

The blade is guided by means of pads and bearings that are set in place during inspection as per the thickness of the blade with minimum play as shown in the figure. In case the blade needs to be replaced, make sure to always install 0.9mm thick blades for which the blade guide pad and bearings have been adjusted.

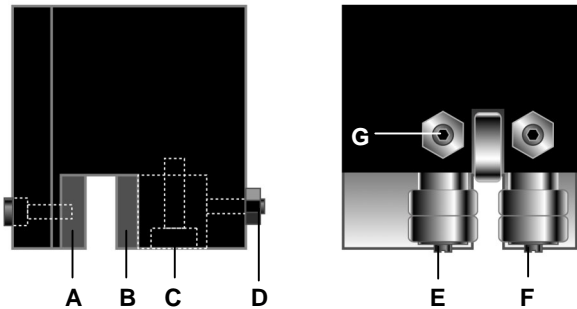

For saw blades with a different thickness, the adjustment should be carried out as follows:  
Note: the position for pad (A) and bearing (F) are fixed and cannot be adjusted.

- Loosen screw (C), nut (D), and setscrew (D) to widening the passage between the pads (A and B).
- Loosen the nut (G) and setscrew (G) and rotate the shaft screw (E) with a flat head screwdriver to widen the passage between the bearings (E and F).
- To mount the new blade: adjust the pad (B) to the blade then loosen the setscrew to allow a play of 0.04 mm for the movement of the saw blade. Lock the nut (D), screw (D), and screw (C), Rotate the shaft (E) until the bearings rest against the blade as indicated in the figure and then secure the setscrew (G) and nut (G).

### 5.3 Saw frame return stroke-limiting device

It consists in a mechanical adjustment system, mounted parallel to the saw frame rise cylinder, to reduce the passive phases of the operating cycle. In other words it eliminates the idle stroke that takes place when the size of the part to be cut is much smaller than the maximum cutting capacity. Practically, you adjust the starting position of the blade in proximity of the part, independently of its dimensions.

Operate as follows:

- Slightly open the flow regulation valve (H).
- Bring the blade as near as 10mm from the work piece with the bow up/bow down switches (C and D).
- Loosen handle (7) to release the adjustable stop (8) against the limit switch (9).
- Lock the handle (7)

ATTENTION:

- It is not necessary to adjust the mechanical stop (8) every time; bring the blade near the workpiece by

means of bow switch (D) and then start the automatic cutting cycle (F), which will begin operation from this position of the blade.

- The bow will return to the upper end stroke.

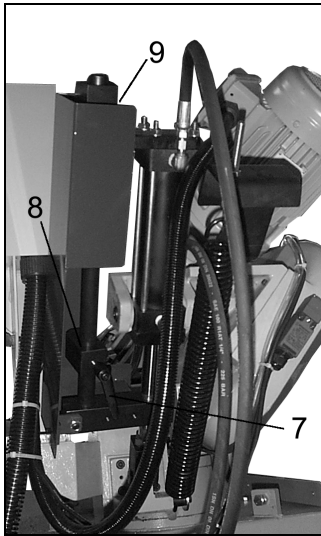

#### 5.4 Changing the blade

To change the blade:

- Lift the saw arm.
- Loosen the blade with the hand wheel, remove the mobile blade-guard cover, open the flywheel guards and remove the old blade from the flywheels and the blade guide blocks.
- Assemble the new blade by placing it first between the pads and then on the race of the flywheels, paying particular attention to the cutting direction of the teeth.
- Tension the blade and make sure it perfectly fits inside the seat of the flywheels.
- Assemble the mobile blade-guide end, the flywheel guard, and fasten it with the relative knobs. Check that the safety microswitch is activated otherwise when electric connection will be restored the machine will not start.

#### 5.5 Adjusting the blade to the flywheels

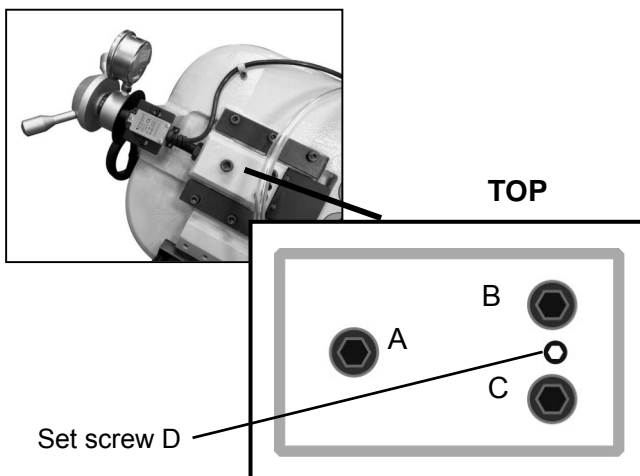

1. Loosen the hex nut screws A, B, and C.
  2. Use an Allen wrench on set screw D to adjust the tilt of the flywheel.
- Turning the set screw D clockwise will tilt flywheel so

that the blade will ride closer to the flange.

-Turning the set screw D counter-clockwise with tilt the flywheels that the blade will ride away from the flange. If the blade rides away too far then it will come off.

After the adjustment is finished, fasten the hex nut screws in this order: A, B, and C.

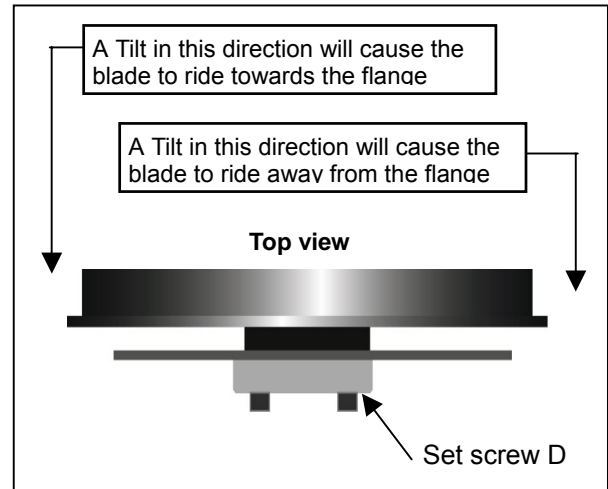

#### Checking the adjustment of the blade

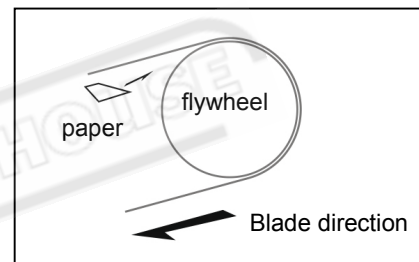

Use a strip of scrap paper and slide it between the blade and the flywheel while it is running.

- if the paper is cut then the blade is riding too close to the flange. Re-adjust.
- if you notice that the blade is riding away from the flange. Then re-adjust.

**WARNING:** Always assemble blades having dimensions specified in this manual and for which the blade guide heads have been set; otherwise, see chapter on "Description of the operating cycle" in the section Starting-up.

#### 5.6 Replacing saw frame return spring

- When performing this operation it is necessary to support saw arm using the lifting device.
- Replace the spring by loosening the upper coupling rod and releasing it from the lower tie-rod.

## 6 ROUTINE AND SPECIAL MAINTENANCE

THE MAINTENANCE JOBS ARE LISTED BELOW, DIVIDED INTO DAILY, WEEKLY, MONTHLY AND SIX-MONTHLY INTERVALS. IF THE FOLLOWING OPERATIONS ARE NEGLECTED, THE RESULT WILL BE PREMATURE WEAR OF THE MACHINE AND POOR PERFORMANCE.

### 6.1 Daily maintenance

- General cleaning of the machine to remove accumulated shavings.
- Clean the lubricating coolant drain hole to avoid excess fluid.
- Top off the level of lubricating coolant.
- Check blade for wear.
- Rise of saw frame to top position and partial slackening of the blade to avoid useless yield stress.
- Check functionality of the shields and emergency stops.

### 6.2 Weekly maintenance

- Thorough cleaning of the machine to remove shavings, especially from the lubricant fluid tank.
- Removal of pump from its housing, cleaning of the suction filter and suction zone.
- Clean the filter of the pump suction head and the suction area.
- Use compressed air to clean the blade guides (guide bearings and drain hole of the lubricating cooling).
- Cleaning flywheel housings and blade sliding surfaces on flywheels.

### 6.3 Monthly maintenance

- Check the tightening of the motor flywheel screws.
- Check that the blade guide bearings on the heads are perfect running condition.
- Check the tightening of the screws of the gear motor, pump, and accident protection guarding.

### 6.4 Six-monthly maintenance

- Continuity test of the equipotential protection circuit.

### 6.5 Maintenance of other machine parts

The worm drive gearbox mounted on the machine is maintenance-free guaranteed by its manufacture.

### 6.6 Oils for lubricating coolant

Considering the vast range of products on the market, the user can choose the one most suited to their own requirements, using as reference the type SHELL LUTEM OIL ECO. THE MINIMUM PERCENTAGE OF OIL DILUTED IN WATER IS 8 - 10 %.

### 6.7 Oil disposal

The disposal of these products is controlled by strict regulations. Please see the Chapter on "**Machine dimensions Transport - Installation**" in the section on *Dismantling*.

### 6.8 The gear box

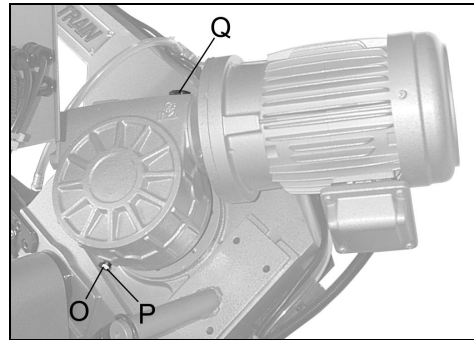

The gear box requires periodic changing of oil. The oil must be changed by the first 6 months of a new machine and every year thereafter.

To change the gear box oil

- Disconnect the machine from the power source.
- Raise the saw arm to vertical position.
- Release the drain hold (O) to draw off gear oil by loosening the hex socket screw (P).
- Replace the screw (P) after oil completely flows off.
- Place the saw arm back to horizontal position.
- Fill Gear box with approximately .3 liter of gear oil through the hole of the vent screw (Q)

For reference, use SHELL type gear oil or Mobile gear oil #90.

### 6.9 Special maintenance

Special maintenance must be conducted by skilled personnel. We advise contacting your nearest dealer and/or importer. Also the reset of protective and safety equipment and devices (of the reducer), the motor, the motor pump, and other electrical components requires special maintenance.

## 7 TECHNICAL CHARACTERISTICS

### 7.1 Table of cutting capacity and technical details

CUTTING CAPACITY			
0°	227	220	260 X 110
45° DX (R)	150	145	200 X 125
60° DX (R)	90	85	
45° DX (L)	110	110	160 X 110

TYPES OF STEEL						CHARACTERISTICS		
USE	I UNI	D DIN	F AF NOR	GB SB	USA. AISI-SAE	Hardness BRINELL HB	Hardness ROCKWELL HRB	R=N/mm <sup>2</sup>
Construction steels	Fe360	St37	E24	----	----	116	67	360÷480
	Fe430	St44	E28	43	----	148	80	430÷560
	Fe510	St52	E36	50	----	180	88	510÷660
Carbon steels	C20	CK20	XC20	060 A 20	1020	198	93	540÷690
	C40	CK40	XC42H1	060 A 40	1040	198	93	700÷840
	C50	CK50	----	----	1050	202	94	760÷900
	C60	CK60	XC55	060 A 62	1060	202	94	830÷980
Spring steels	50CrV4	50CrV4	50CV4	735 A 50	6150	207	95	1140÷1330
	60SiCr8	60SiCr7	----	----	9262	224	98	1220÷1400
Alloyed steels for hardening and tempering and for nitriding	35CrMo4	34CrMo4	35CD4	708 A 37	4135	220	98	780÷930
	39NiCrMo4	36CrNiMo4	39NCD4	----	9840	228	99	880÷1080
	41CrAlMo7	41CrAlMo7	40CADG12	905 M 39	----	232	100	930÷1130
Alloyed casehardening steels	18NiCrMo7	----	20NCD7	En 325	4320	232	100	760÷1030
	20NiCrMo2	21NiCrMo2	20NCD2	805 H 20	4315	224	98	690÷980
Alloyed for bearings	100Cr6	100Cr6	100C6	534 A 99	52100	207	95	690÷980
Tool steel	52NiCrMoKU	56NiCrMoV7C100K	----	----	----	244	102	800÷1030
	C100KU	C100W1	----	BS 1	S-1	212	96	710÷980
	X210Cr13KU	X210Cr12	Z200C12	BD2-BD3	D6-D3	252	103	820÷1060
	58SiMo8KU	----	Y60SC7	----	S5	244	102	800÷1030
Stainless steels	X12Cr13	4001	----	----	410	202	94	670÷885
	X5CrNi1810	4301	Z5CN18.09	304 C 12	304	202	94	590÷685
	X8CrNi1910	----	----	----	----	202	94	540÷685
	X8CrNiMo1713	4401	Z6CDN17.12	316 S 16	316	202	94	490÷685
Copper alloys Special brass Bronze	Aluminium copper alloy G-CuAl11Fe4Ni4 UNI 5275					220	98	620÷685
	Special manganese/silicon brass G-CuZn36Si1Pb1 UNI5038					140	77	375÷440
	Manganese bronze SAE43 - SAE430					120	69	320÷410
	Phosphor bronze G-CuSn12 UNI 7013/2a					100	56,5	265÷314
Cast iron	Gray pig iron		G25			212	96	245
	Spheroidal graphite cast iron		GS600			232	100	600
	Malleable cast iron		W40-05			222	98	420

ELECTRIC MOTOR-BLADE ROTATION	kW	0.59 / 1.1
HYDRAULIC UNIT MOTOR	kW	0.4
COOLING PUMP ELECTRIC MOTOR	kW	0.09
REDUCTION UNIT IN OIL BATH	I	40:1
FLYWHEEL DIAMETER	mm	295
BLADE DIMENSIONS	mm	27x0.9x2460
BLADE SPEED CUTTING	m/min	36 / 72
OPENING VICE	mm	260
SAW FRAME TILTING	°	40
WORKING TABLE HEIGHT	mm	900
MACHINE WEIGHT	kg	380

## 8 MATERIAL CLASSIFICATION AND CHOICE OF TOOL

Since the aim is to obtain excellent cutting quality, the various parameters such as hardness of the material, shape and thickness, transverse cutting section of the part to be cut, selection of the type of cutting blade, cutting speed and control of saw frame lowering. These specifications must therefore be harmoniously combined in a single operating condition according to practical considerations and common sense, so as to achieve an optimum condition that does not require countless operations to prepare the machine when there are many variations in the job to be performed. The various problems that crop up from time to time will be solved more easily if the operator has a good knowledge of these specifications.

### 8.1 Definition of materials

The table above lists the characteristics of the materials to be cut. So as to choose the right tool to use.

### 8.2 Selecting blade

First of all the pitch of the teeth must be chosen, in other words, the number of teeth per inch (25,4 mm) suitable for the material to be cut, according to these criteria:

- Parts with a thin and/or variable section such as profiles, pipes and plate, need close toothing, so that the number of teeth used simultaneously in cutting is from 3 to 6;
- Parts with large transverse sections and solid sections need widely spaced toothing to allow for the greater volume of the shavings and better tooth penetration;
- Parts made of soft material or plastic (light alloys, mild bronze, Teflon, wood, etc.) also require widely spaced toothing;
- Pieces cut in bundles require combo tooth design.

### 8.3 Teeth pitch

As already stated, this depends on the following factors:

- **Hardness of the material**
- **Dimensions of the section**
- **Wall thickness.**

BLADE TEETH SELECTION TABLE		
THICKNESS mm	Z CONTINUOUS TOOTH DESIGN	Z COMBO TOOTH DESIGN
TILL 1.5	14	10/14
FROM 1 TO 2	8	8/12
FROM 2 TO 3	6	6/10
FROM 3 TO 5	6	5/8
FROM 4 TO 6	6	4/6
MORE THAN 6	4	4/6

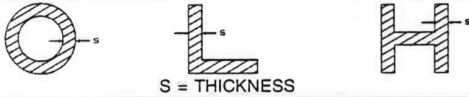

SOLID Ø OR L mm	Z CONTINUOUS TOOTH DESIGN	Z COMBO TOOTH DESIGN
TILL 30	8	5/8
FROM 30 TO 60	6	4/6
FROM 40 TO 80	4	4/6
MORE THAN 90	3	3/4



### 8.4 Cutting and advance speed

The cutting speed (m/min) and the advance speed (cm<sup>2</sup>/min = area traveled by the disk teeth when removing shavings) are limited by the development of heat close to the tips of the teeth.

- The cutting speed is subordinate to the resistance of the material ( $R = N/mm^2$ ), to its hardness (HRC) and to the dimensions of the widest section.
- Too high an advance speed (= lowering of the saw frame) tends to cause the disk to deviate from the ideal cutting path, producing non rectilinear cuts on both the vertical and the horizontal plane.

The best combination of these two parameters can be seen directly examining the chips.

Long spiral-shaped chips indicate ideal cutting.

Very fine or pulverized chips indicate lack of feed and/or cutting pressure.

Thick and/or blue chips indicate overload of the blade.

### 8.5 Blade running-in

**When cutting for the first time, it is good practice to run in the tool making a series of cuts at a low advance speed (= 30-35 cm<sup>2</sup>/min on material of average dimensions with respect to the cutting capacity and solid section of normal steel with  $R = 410-510 N/mm^2$ ). Generously spraying the cutting area with lubricating coolant.**

### 8.6 Blade structure

Bi-metal blades are the most commonly used. They consist of a silicon-steel blade backing by a laser welded high speed steel (HSS) cutting edge. The type of stocks are classified in M2, M42, M51 and differ from each other because of their major hardness due to the increasing percentage of Cobalt (Cc) and molybdenum (Mo) contained in the metal alloy

### 8.7 Blade type

They differ essentially in their constructive characteristics, such as:

- **Shape** and cutting **angle** of tooth
- **Pitch**
- **Set**

#### Shape and angle of tooth

**REGULAR TOOTH:** 0° rake and constant pitch.



Most common form for transversal or inclined cutting of solid small and average cross-sections or pipes, in laminated mild steel and gray iron or general metal.

**POSITIVE RAKE TOOTH:** 9° - 10° positive rake and constant pitch.

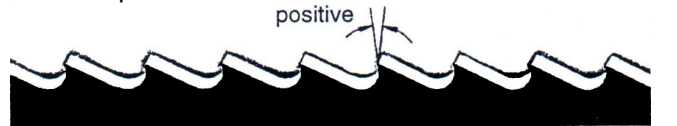

Particular use for crosswise or inclined cuts in solid sections or large pipes, but above all harder materials (highly alloyed and stainless steels, special bronze and forge pig iron).

**COMBO TOOTH:** pitch varies between teeth and consequently varying teeth size and varying gullet depths. Pitch varies between teeth, which ensures a smoother, quieter cut and longer blade life owing to the lack of vibration.

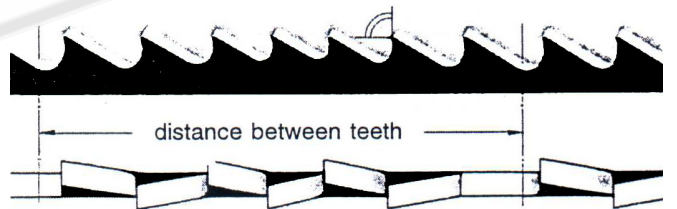

Another advantage offered in the use of this type of blade in the fact that with an only blade it is possible to cut a wide range of different materials in size and type.

**COMBO TOOTH:** 9° - 10° positive rake.

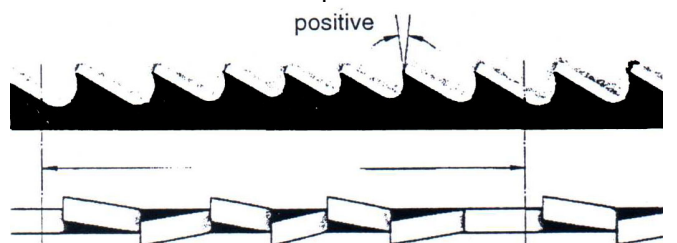

This type of blade is the most suitable for the cutting of section bars and large and thick pipes as well as for the cutting of solid bars at maximum machine capacity. Available pitches: 3-4/4-6.

### SETS

Saw teeth bent out of the plane of the saw body, resulting in a wide cut in the workpiece.

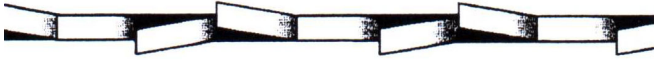

**REGULAR OR RAKER SET:** Cutting teeth right and left, alternated by a straight tooth.

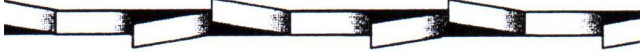

Of general use for materials with dimensions superior to 5 mm. Used for the cutting of steel, castings and hard nonferrous materials.

**WAVY SET:** Set in smooth waves.



This set is associated with very fine teeth and it is mainly used for the cutting of pipes and thin section bars (from 1 to 3 mm).

**ALTERNATE SET (IN GROUPS):** Groups of cutting teeth right and left, alternated by a straight tooth.



This set is associated with very fine teeth and it is used for extremely thin materials (less than 1mm).

**ALTERNATE SET (INDIVIDUAL TEETH):** Cutting teeth right and left.



This set is used for the cutting of nonferrous soft materials, plastics and wood.

## 9 NOISE TESTS

The test was held under environmental noise levels of 65db. Noise measurements with the machine operating unload was 71db. Noise level during the cutting of mild carbon steel was 73db.

NOTE: with the machine operating, the noise level will vary according to the different materials being processed. The user must therefore assess the intensity and if necessary provide the operators with the necessary personal protection, as required by Law 277/1991.

MACHINERYHOUSE

# 10 WIRING DIAGRAMS

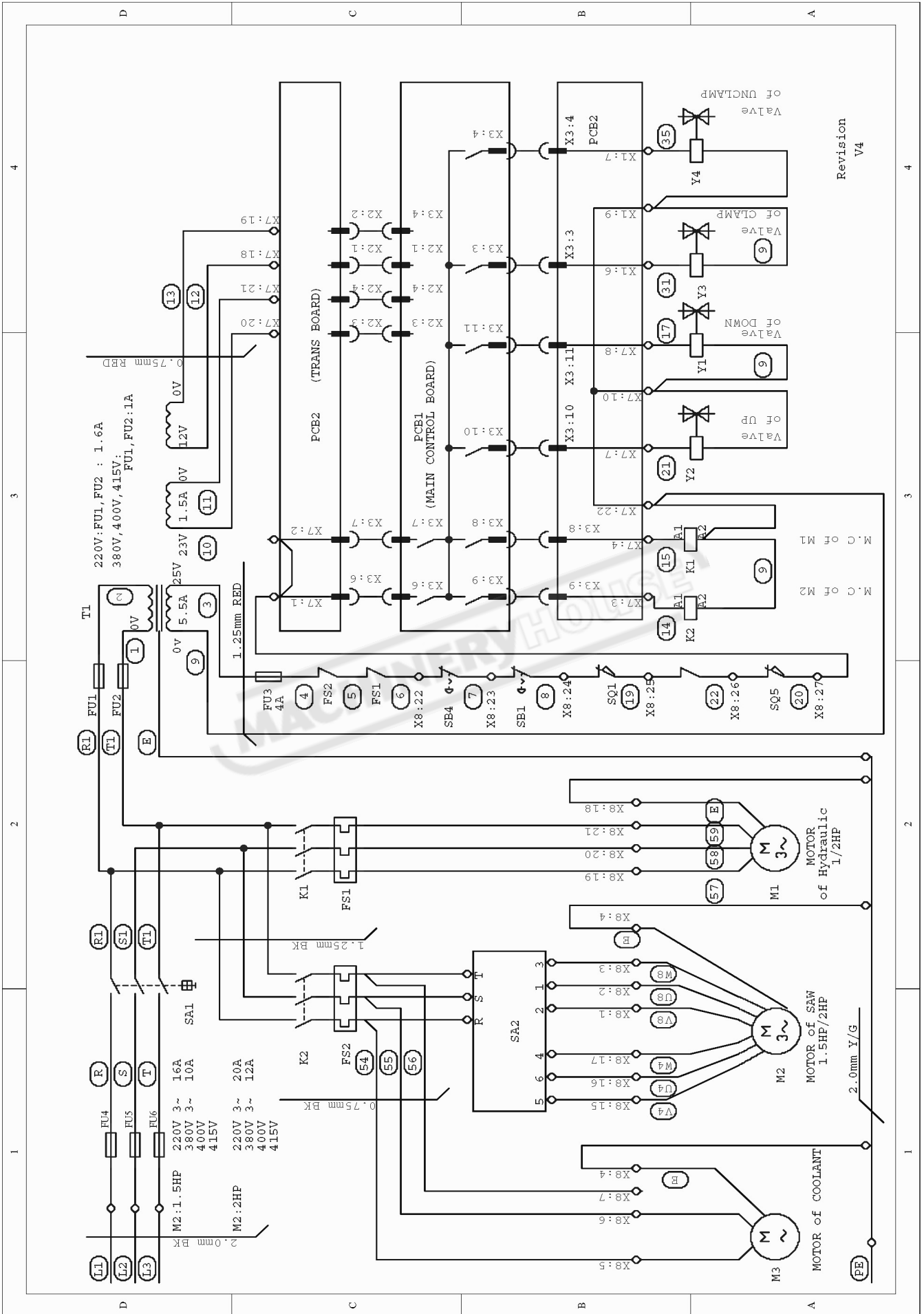

Revision V4

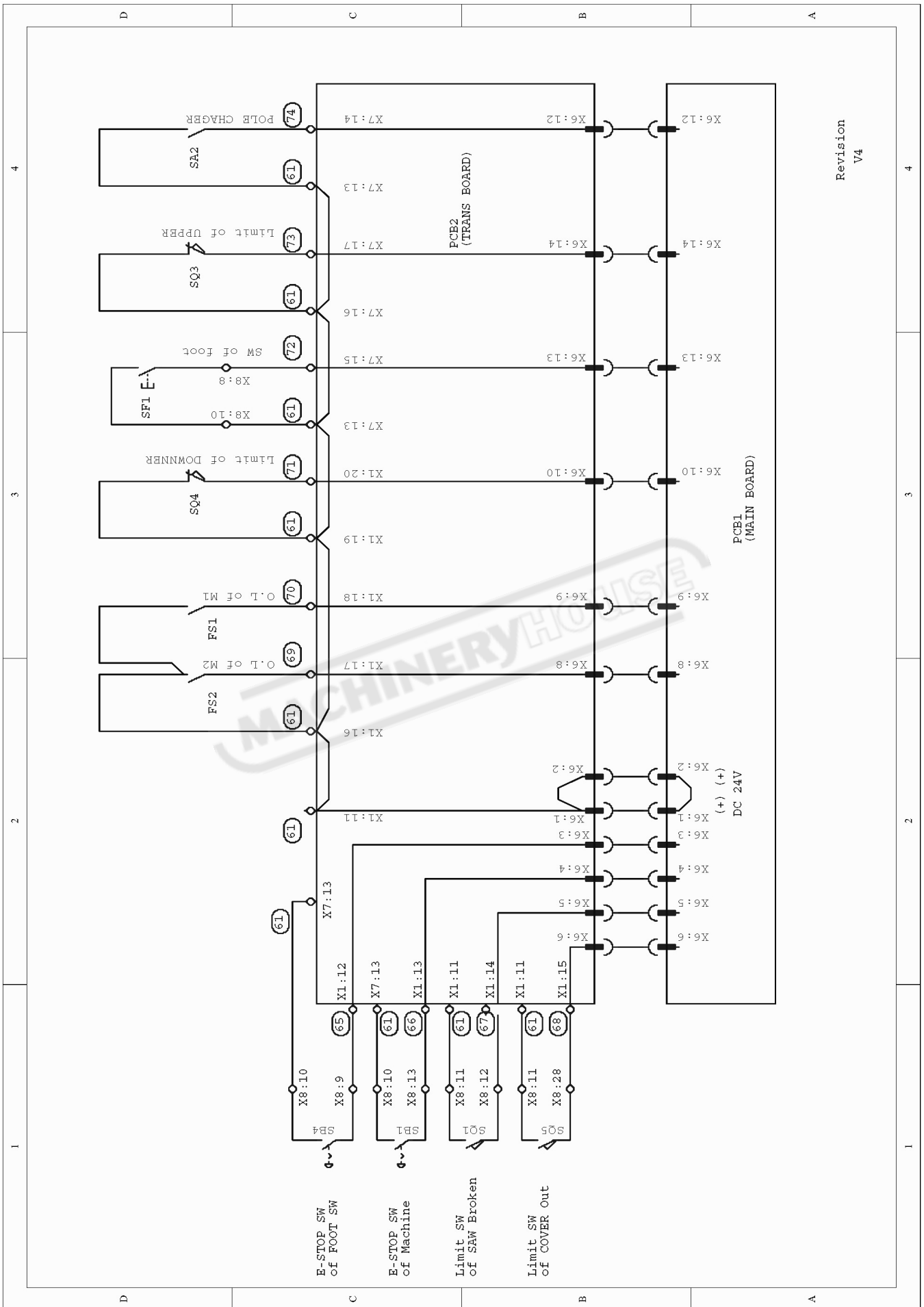

Revision V4

## 11 TROUBLESHOOTING

This chapter lists the probable faults and malfunctions that could occur while the machine is being used and suggests possible remedies for solving them.

The first paragraph provides diagnosis for TOOLS and CUTS the second for ELECTRICAL COMPONENTS.

### 11.1 - Electrical components diagnosis

<b>FAULT</b>	<b>PROBABLE CAUSE</b>	<b>REMEDY</b>
1. No Power	Blown fuse	If a fuse is blown, check the related components for an over-load or short-circuit.
	A. No operation on three-phase	Check the power supply and fuses No. FU4, FU5, FU6 for normal condition.
	B. No DC24V (The white indicator light is failed on the panel)	a. Check the transformer's inputs FU1 and FU2(1A/1.6A) for normal condition. b. Check fuse FU1(1A) on PCB1 for normal condition.
	C. No DC5V (The rest of indicator lights are failed.)	a. Check the transformer's inputs FU1 and FU2(1A) for normal condition. b. Check fuse FU2(1A) on PCB1 for normal condition.
	D. No AC24V power	a. Check the transformer's inputs FU1 and FU2(1A) for normal condition. b. Check fuse FU3(4A) on the distributor board for normal condition. c. Check the connection points of the safety limit switches at their locations on the machine for normal condition -refer to the wire diagram No: WT/M3/C-01, connection wire No. 4, 5, 6, 7, 8, 19, and 20.
2. Hydraulic pump	Failure	a. Check on hydraulic motor M1, and see if it works. b. Check the pump for normal condition. c. Check AC contactor K1 for normal condition or over-load (FS1). d. Check the distributor board for voltage flow to Coil K1(Wire No. 9 and 15).
	Pump works but low pressure	a. Check the hydraulic motor M1 wiring for correct three phase connections. b. Check the hydraulic flow for normal condition-without staleness, shortage, or leaking.
3. Saw bow	No operation	a. Check the hydraulic pump. b. Check the hydraulic flow for normal condition. c. Check the distributor board for voltage flow to Coil K1(Wire No. 9 and 15). d. Check the signal of the hydraulic magnetic valve for normal condition ( Bow up wire No. 9 and 21; bow down wire No. 9 and 17.)
4. Vise (Front, back)	No operation	a. Check the hydraulic pump. b. Check the hydraulic flow for normal condition. c. Check the control panel for voltage flow to Coil K1(Wire No. 9 and 15). d. Check the signal of the hydraulic magnetic valve for normal condition ( Vise close wire No. 9 and 31; vise open wire No. 9 and 35.)

<b>FAULT</b>	<b>PROBABLE CAUSE</b>	<b>REMEDY</b>
5. Saw blade	Doesn't work	<ul style="list-style-type: none"> <li>a. Check saw blade motor M2 for normal condition.</li> <li>b. Check the motor's speed-exchanging switch for normal condition.</li> <li>c. Check the AC contactor K2 for normal condition or over-load (FS2).</li> <li>d. Check on the distributor board for voltage flow to Coil K2 (Wire No. 9 and 14).</li> </ul>
	Reversing	Check the blade motor M2 the wiring of motor phases.
6. Control panel	No operation	<ul style="list-style-type: none"> <li>a. Check DC24V and DC5V (check the related components for an over-load or short-circuit.)</li> <li>b. Check the switches and see if each one is correctly positioned.(Refer to page 4: Other functions descriptions.)</li> </ul>
7. Speed-exchanging switch's	Indicator light blinking	<ul style="list-style-type: none"> <li>a. Check the speed-exchange switch position.</li> <li>b. Check the speed-exchange switch for working order.</li> <li>c. Check the DC24V power supply for normal condition.</li> </ul>
8. Saw Blade	Blade-broken indicator light blinking	<ul style="list-style-type: none"> <li>a. Check the blade for damage or improper placement on flywheels.</li> <li>b. Check the limit switches for normal conditions (Check connection for wire No. 61 and 67.)</li> </ul>
9. Blade cover	Indicator light blinking	<ul style="list-style-type: none"> <li>a. Check the blade covers, and see if both are properly located and closed.</li> <li>b. Check the limit switches for normal condition (Check the connection for wire No. 61 and 68.)</li> </ul>
10. Motor M1, M2	Over-loaded indicator light blinking	<ul style="list-style-type: none"> <li>a. Check the motor-loading for normal condition (neither over-loaded or short-circuited.)</li> <li>b. Check the wire connections for normal condition (Check the connection points for wire No. 61, and 70 on FS1, No. 61, 69 on FS2.)</li> </ul>
11. Saw bow Up & Down	Limit switches indicators blinking at the same time	<p>This means the both limit switches are being pressed at the same time.</p> <ul style="list-style-type: none"> <li>a. Check the DC24V power supply for normal condition.</li> <li>b. Check connections for each limit switch and that the wires are correctly connected (Check the Up limit switch, wires No. 61, 73; Down limit switch, wires No. 61, 71.)</li> </ul>
12. Emergency button	Indicator light blinking	<ul style="list-style-type: none"> <li>a. See if the emergency switch is stuck.</li> <li>b. Check the wire connections ( Wires No. 61, 66 in the emergency switch on saw body; wires No. 61, 65 for the emergency switch on the food pad control.)</li> </ul>
13. Foot pad	Switch not working	<ul style="list-style-type: none"> <li>a. Check the Hand/foot pad control operation selector (E) is properly switched.</li> <li>b. Check for foot pad switch is in working order.</li> <li>c. Check the wire No. 61, 72 for OK signal.</li> </ul>
14. Other indicator lights	Warning signal	Refer to page4: Other functions descriptions.

## 11.2 - Blade and cut diagnosis

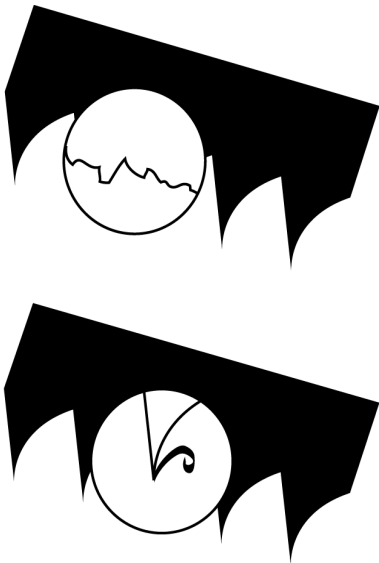
FAULTPROBABLE CAUSEREMEDY**TOOTH BREAKAGE**

Too fast advance

Wrong cutting speed

Wrong tooth pitch

Chips sticking onto teeth and in the gullets or material that gums

Defects on the material or material too hard

Ineffective gripping of the part in the vise

The blade gets stuck in the material

Starting cut on sharp or irregular section bars

Poor quality blade

Previously broken tooth left in the cut

Cutting resumed on a groove made previously

Vibrations

Wrong tooth pitch or shape

Insufficient lubricating, refrigerant, or wrong emulsion

Teeth positioned in the direction opposite the cutting direction

Decrease advance, exerting less cutting pressure. Adjust the braking device.

Change speed and/or type of blade. See chapter on "**Material classification and blade selection**", in the section *Blade selection table according to cutting and feed speed*.

Choose a suitable blade. See Chapter "**Material classification and blade selection**".

Check for clogging of coolant drain holes on the blade-guide blocks and that flow is plentiful in order to facilitate the removal of chips from the blade.

Material surfaces can be oxidized or covered with impurities making them, at the beginning of the cut, harder than the blade itself, or have hardened areas or inclusions inside the section due to productive agents used such as casting sand, welding wastes, etc. Avoid cutting these materials or in a situation a cut has to be made use extreme care, cleaning and remove any such impurities as quickly as possible.

Check the gripping of the part.

Reduce feed and exert less cutting pressure.

Pay more attention when you start cutting.

Use a superior quality blade.

Accurately remove all the parts left in.

Make the cut elsewhere, turning the part.

Check gripping of the part.

Replace blade with a more suitable one. See "**Material classification and blade selection**" in the *Blade Types* section. Adjust blade guide pads.

Check level of liquid in the tank. Increase the flow of lubricating refrigerant, checking that the hole and the liquid outlet pipe are not blocked. Check the emulsion percentage.

Turn teeth to correct direction.

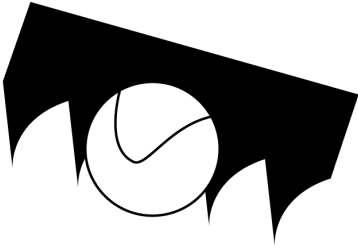
**FAULT****PREMATURE BLADE WEAR****PROBABLE CAUSE**

Faulty running-in of blade

Teeth positioned in the direction opposite the cutting direction

Poor quality blade

Too fast advance

Wrong cutting speed

Defects on the material or material too hard

Insufficient lubricating refrigerant or wrong emulsion

**REMEDY**

See "Material classification and blade selection" in the *Blade running-in* section.

Turn teeth in correct direction.

Use a superior quality blade.

Decrease advance, exerting less cutting pressure. Adjust the braking device.

Change speed and/or type of blade. See chapter on "**Material classification and blade selection**", in the section *Blade selection table according to cutting and feed speed*.

Material surfaces can be oxidized or covered with impurities making them, at the beginning of the cut, harder than the blade itself, or have hardened areas or inclusions inside the section due to productive agents used such as casting sand, welding wastes, etc. Avoid cutting these materials or perform cutting with extreme care, cleaning and remove such impurities as quickly as possible.

Check level of liquid in the tank. Increase the flow of lubricating coolant, checking that the coolant nozzle and pipe are not blocked. Check the emulsion percentage.

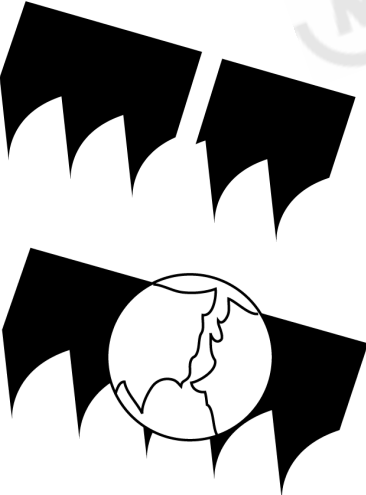
**BLADE BREAKAGE**

Faulty welding of blade

Too fast advance

Wrong cutting speed

Wrong tooth pitch

Ineffective gripping of the part in the vice

Blade touching material at beginning of cut

Remedy

The welding of the blade is of utmost importance. The meeting surfaces must perfectly match and once they are welded they must have no inclusions or bubbles; the welded part must be perfectly smooth and even. They must be evenly thick and have no bulges that can cause dents or instant breakage when sliding between the blade guide pads.

Decrease advance, exerting less cutting pressure. Adjust the braking device.

Change speed and/or type of blade.

See chapter on "**Material classification and blade selection**", in the section *Blade selection table according to cutting and feed speed*.

Choose a suitable blade. See Chapter "**Material classification and blade selection.**"

Check the gripping of the part.

At the beginning of the cutting process, never lower the saw bow before starting the blade motor.

**FAULT**

**PROBABLE CAUSE**

**REMEDY**

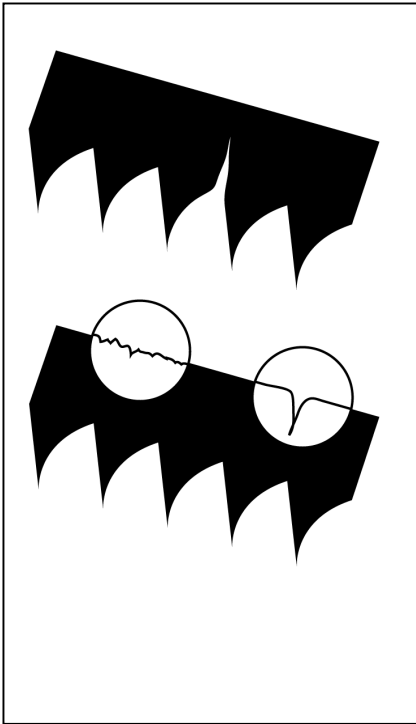

Blade guide pads not regulated or dirty because of lack of maintenance

Blade guide block too far from material to be cut

Improper position of blade on flywheels

Insufficient lubricating coolant or wrong emulsion

Check distance between pads (see "**Machine adjustments**" in the *Blade Guide Blocks* section): extremely accurate guiding may cause cracks and breakage of the tooth. Use extreme care when cleaning.

Approach head as near as possible to material to be cut so that only the blade section employed in the cut is free, this will prevent deflections that would excessively stress the blade.

The back of blade rubs against the support due to deformed or poorly welded bands (tapered), causing cracks and swelling of the back contour.

Check level of liquid in the tank. Increase the flow of lubricating refrigerant, checking that the hole and the liquid outlet pipe are not blocked. Check the emulsion percentage.

**STEAKED OR ETCHED BANDS**

Damaged or chipped blade guide pads

Tight or slackened blade guide bearings.

Replace them.

Adjust them (see Chapter "**Machine adjustments**" in *Blade guide* section).

**CUTS OFF THE STRAIGHT**

Blade not parallel as to the counter service

Blade not perpendicular due to the excessive play between the guide pads and maladjustment of the blocks

Too fast advance

Worn out blade

Wrong tooth pitch

Check fastenings of the blade guide blocks as to the counter-vice so that they are not too loose and adjust blocks vertically; bring into line the position of the degrees and if necessary adjust the stop screws of the degree cuts.

Check and vertically re-adjust the blade guide blocks; reset proper side guide play (see Chapter "**Machine adjustments**" in *Blade guide* section).

Decrease advance, exerting less cutting pressure. Adjust the braking device.

Approach it as near as possible to material to be cut so that only the blade section employed in the cut is free, this will prevent deflections that would excessively stress the blade.

Replace it. Blade with major density of teeth is being used, try using one with less teeth (see Chapter "**Material classification and blade selection**" in the *Blade Types* section).

**FAULT**

**PROBABLE CAUSE**

**REMEDY**

	<p>Broken teeth</p> <p>Insufficient lubricating refrigerant or wrong emulsion</p>	<p>Irregular work of the blade due to the lack of teeth can cause deflection in the cut; check blade and if necessary replace it.</p> <p>Check level of liquid in the tank. Increase the flow of lubricating coolant, checking that the hole and the liquid outlet pipe are not blocked. Check the emulsion <i>percentage</i>.</p>
--	---	--

<p><b>FAULTY CUT</b></p>	<p>Worn out flywheels Flywheel housing full of chips</p>	<p>The support and guide flange of the band are so worn out that they cannot ensure the alignment of the blade, causing faulty cutting; blade rolling and drawing tracks can have become tapered. Replace them. Clean with compressed air.</p>
--------------------------	--	--

<p><b>STREAKED CUTTING SURFACE</b></p> 	<p>Too fast advance</p> <p>Poor quality blade</p> <p>Worn out blade or with chipped and/or broken teeth</p> <p>Wrong tooth pitch</p> <p>Blade guide block too far from material to be cut</p> <p>Insufficient lubricating coolant or wrong emulsion</p>	<p>Decrease advance, exerting less cutting pressure. Adjust the braking device.</p> <p>Use a superior quality blade.</p> <p>Replace it.</p> <p>Blade used probably has too large teeth, use one with more teeth (see "<b>Material classification and blade selection</b>" in the <i>Blade Types</i> section).</p> <p>Approach it as near as possible to material to be cut so that only the blade section employed in the cut is free, this will prevent deflections that would excessively stress the blade.</p> <p>Check level of liquid in the tank. Increase the flow of lubricating coolant, checking that the hole and the liquid outlet pipe are not blocked. Check the emulsion <i>percentage</i>.</p>
---	---	--

<p><b>NOISE ON GUIDE BLOCKS</b></p>	<p>Chipped bearings Worn out or damaged pads</p>	<p>Dirt and/or chips between blade and guide bearings. Replace them. Replace them.</p>
-------------------------------------	--	--

## 12 MACHINE COMPONENTS

### 12.1 PART LIST

Part No.	Description	Size No.	Q'ty	Part No.	Description	Size No.	Q'ty
1	Base (Bottom Plate)		1	47	Roller		1
2	Base (Left Part)		1	48	Ball Bearing	6004ZZ	2
2-1	Nut	M8	2	48-1	C-Ring	S-20	2
3	Base (Right Part)		1	49	Roller Shaft		1
4	Base (Front Part)		1	50	Hex. Socket Cap Screw	M10x20	2
4-1	Hex. Cap Bolt	M8x16	2	50-1	Spring Washer	M10	2
4-2	Washer	M8	4	51	Pedal Plate		1
5	Hex. Cap Bolt	M12x40	2	53	Pedal Switch		1
6	Nut	M12	2	53-1	Micro Switch		1
8	Hex. Cap Bolt	M8x16	6	54	Round Head Screw	M4x10	4
8-1	Washer	M8	6	55	Hex. Socket Cap Screw	M6x8	1
9	Plate		1	56A	Emergency Switch Box		1
10	Hex. Socket Cap Screw	M5x8	4	56-1	Pipe		1
11	Coolant Tank		1	57-1	Flat Head Cross Screw		4
12	Hex. Cap Bolt	M8x16	2	58	Hex. Socket Cap Screw	M5x8	4
13	Coolant Gauge		1	58-1	Nut	M4	4
13-1	Nut	M10	2	59A	Emergency Switch		1
13-2	Washer	M10	2	60A	Handle		1
14	Hex. Cap Bolt	3/16"	2	60-1	Hex. Socket Cap Screw	M8x20	2
15	Tank Cover		1	60-2	Nut	M8	2
16	Filter		1	61	Handle		1
17	Pump		1	61-1	Nut	M12	1
18	Hex. Socket Cap Screw	M6x25	2	63	Locking Lever		1
18-1	Washer	M6	2	63-1	Set Screw	M8x10	1
22	Hose Clamp	13mm	1	64	Hex. Socket Cap Screw	M10x35	1
23	Hose	5/16"x235cm	1	64-1	Spring Washer	M10	1
23-1	Hose	1"x45cm	1	65	Shaft Nut		1
24	Coolant and Chip Tray		1	65-1	Oil Seal		1
24-1	Block Plate		1	65-3	Disk		1
25	Mounting Bracket		2	65-4	Spring Washer	M8	4
26	Spring Washer	M10	4	65-5	Hex. Socket Cap Screw	M8x30	4
27	Hex. Socket Cap Screw	M10x20	4	66A	Shaft		1
28	Washer	M10	4	68	Swivel Arm		1
29	Hex. Cap Bolt	M10x20	4	68-1	Hex. Cap Bolt	M10x35	1
29-1	Washer	M10	4	69	Scale		1
30	Hex. Cap Bolt	M12x40	2	70	Rivet	2.3x4	2
31	Nut	M12	2	71	Pin		1
32	Scale		1	72	Hollow Pin	∅ 2.5x16	1
33	Round Head Screw	M5x10	2	73	Spring		1
34	Nut		1	74	Bushing		1
34-1	Washer	M34	1	75	Bracket		1
35	Switch		1	76	Spring Washer	M8	2
36	Emergency Switch		1	77	Hex. Socket Cap Screw	M8x25	2
37	Grommet		2	78	Knob		1
38	Grommet		1	79	Jam Nut	M35	1
39	Track		1	80	Star Washer	M35	1
40	Hex. Socket Cap Screw	M8x35	2	81	Anti-Dust Cover	M35	2
40-1	Nut	M8	2	82	Ball Bearing	32007	2
40-2	Spring Washer	M8	2	83	Shaft		1
41	Set Screw	M6x12	4	84	Hex. Cap Bolt	M10x45	1
42	Washer		1	85	Nut	M10	2
43	Handle	M8x25	1	86A	Pointer		1
44	Roller Stand		1	87	Hex. Socket Cap Screw	M5x8	1
45	Hex. Cap Bolt	M12x25	2	88-2	Set Screw	M8x10	1
46	Spring Washer	M12	2	92B	Table		1
46-1	Washer	M12	2	92-1	Set Screw	M6x12	1

1000615

**PART LIST**

Part No.	Description	Size No.	Q'ty	Part No.	Description	Size No.	Q'ty
92-2	Changeable Plate		1	151	Reduction Unit		1
92-3	Hex. Socket Cap Screw	M8x16	4	152	Key	8x8x30	1
94	Bar-Stop-Rod		1	152-1	Vent Screw		1
95	Bar-Stop		1	153	Hex. Cap Bolt	M8x30	4
96	Handle	M10x35	1	153-1	Spring Washer	M8	4
97	Scale		1	154	Motor		1
98	Rivet		3	154-1	Junction Box		1
102	No-Burr Jaw		1	155	Key	8x7x35	1
103	Hex. Socket Cap Screw	M6x20	2	156	Anchoring Dowel		1
104	Counter Vise Jaw		1	157	Hex. Socket Cap Screw	M8x25	4
105	Hex. Socket Cap Screw	M6x15	2	157-1	Spring Washer	M8	4
106	Vise Jaw		1	158	Hollow Pin	∅6x20	2
107	Flat Head Machine Screw	M6x15	2	159	Coupling Fork		1
108	Vise		1	160	Pin on Fork		1
109	Dovetail Plate		1	161	C-Ring	S-20	2
110	Nut	M5	3	162	Nut		1
111	Set Screw	M5x25	3	163	Rod Supporting Block		1
112	Vise Screw for Hydraulic Drive		1	164	Hex. Socket Cap Screw	M10x30	1
112-1	Hex. Socket Cap Screw	M8x16	1	164-1	Spring Washer	M10	2
112-2	Washer	M8	1	165	Nut	M10	1
113	Key	5x5x15	1	166	Hex. Socket Cap Screw	M10x40	1
114	Hydraulic Cylinder (Vise)		1	167	Adjustable Stop		1
115	Spring Washer	M8	4	168	Handle	M8x25	1
116	Hex. Socket Cap Screw	M8x25	4	169	Stop Bar		1
117	Hand Wheel		1	170	Adjustable Stop		1
117-1	Spring Washer	M6	1	170-1	Set Screw	M8x10	1
117-2	Hex. Socket Cap Screw	M6x25	1	171	Hydraulic Cylinder (Arm)		1
117-3	Bushing		1	172	Bushing		2
118	Set Screw	M8x10	1	173	Hex. Socket Cap Screw	M12x20	2
120	Vise Seat		1	174A	Limit Switch Plate		1
122	Vise Setting Plate		1	175	Spring Washer	M8	4
123	Hex. Socket Cap Screw	M10x35	2	176	Nut	M8	4
124	Washer	3/4"x37x3	1	177	Spring Washer	M6	2
125	Lock Lever Device		1	178	Hex. Socket Cap Screw	M6x12	2
127	Handle		1	179	Limit Switch		2
128	Setting Plate		1	180	Hex. Socket Cap Screw	M6x25	4
129	Bushing		1	181	Spring Holder		1
130	Hex. Socket Cap Screw	M8x20	2	182	Nut	M8	2
130-1	Spring Washer	M8	2	183	Hex. Cap Bolt	M12x30	2
131	Electric Box Holder		1	183-1	Spring Washer	M12	2
132	Spring Washer	M8	4	184	Cylinder Guard		1
133	Hex. Socket Cap Screw	M8x20	4	185	Hex. Socket Cap Screw	M6x60	2
135	Hex. Socket Cap Screw	M10x25	2	185-1	Hex. Socket Cap Screw	M5x8	1
136	Spring Washer	M10	2	186	Hex. Socket Cap Screw	M10x35	4
138	Hex. Socket Cap Screw	M6x25	2	186-1	Spring Washer	M10	4
138-1	Washer	M6	2	187	Cylinder Coupling		1
139	Nut	M6	2	188	Spring Hook	3/8"	1
140-5	Magnetic Switch		2	189	Spring		1
140-6	Overload Relay	1.2A	1	190	Setting Bushing		1
140-8	Hex. Cap Bolt	M6x15	2	191	Washer	M8	1
140-11	Overload Relay		1	192	Hex. Socket Cap Screw	M8x35	1
142	Hex. Socket Cap Screw	M5x8	10	193A	Saw Arm		1
143	Nut	M5	4	194	Hex. Socket Cap Screw	M10x30	4
146	Round Head Screw	M5x10	4	194-1	Spring Washer	M10	4
147-2	Main Connect Switch		1	195	Limit Switch		1
147-5	Speed Selector		1	195-1	Switch Pin		1

1000615

**PART LIST**

Part No.	Description	Size No.	Q'ty	Part No.	Description	Size No.	Q'ty
196	Hex. Socket Cap Screw	M4x35	2	260	Hex. Socket Cap Screw	M6x8	1
197	Hex. Socket Cap Screw	M10x35	4	261	Blade Guard		1
197-1	Spring Washer	M10	4	262	Set Screw	M6x20	2
198	Pipe Fitting Seat		1	263	Nut	M6	2
199	Hex. Socket Cap Screw	M5x30	2	264	Centric Shaft		2
200	Coolant Switch		1	265	Ball Bearing	608ZZ	8
201	Hose Clamp	13mm	1	265-1	Ball Bearing	608ZZ	2
203	Pipe Fitting	1/4Px5/16	2	266	E-Ring	E-7	4
204	Hose	5/16"x40cm	1	267	Blade Guide		2
205	Hose	5/16"x90cm	1	268	Hex. Socket Cap Screw	M6x25	2
206	Drive Flywheel		1	269	Eccentric Shaft		2
207	Washer		1	270	Hex. Socket Cap Screw	M6x8	2
207-1	Spring Washer	M10	1	271	Blade Guard		1
208	Hex. Cap Bolt	M10x25	1	272	Guide Bracket		1
209A	Idle Flywheel Shaft		1	272-1	Hex. Socket Cap Screw	M6x8	2
210	Roller Bearing	32006	2	273	Pipe Fitting		1
211	Idle Flywheel		1	274	Blade Guide		2
212	Star Washer	M30	1	275	Ball Bearing Bracket		1
212-1	Anti-dust Cover	M30	2	276	Set Screw	M6x12	4
213	Jam Nut	M30	1	277	Hex. Socket Cap Screw	M10x20	2
214	Oil Inlet	1/16	1	279	Hex. Socket Cap Screw	M8x20	2
215	Saw Blade		1	280	Brush		1
216	Blade Cover		1	281	Brush Clamp		1
217	Plum Screw	M6x10	4	282	Set Screw	M5x5	1
219	Round Head Screw	M4x8	2	283	Set Bushing		1
220	Nut	M4	2	284	Hex. Cap Bolt	M6x12	2
222	Handle		2	285	Washer	M6	2
223	Handle Wheel		1	326A	Flow Control		1
223-1	Thrust Bearing	51103	1	327A	Hose	2.5 meters	1
223-2	Blade Tension Gauge		1	328A	Hose	2.0 meters	1
223-3	Plate		1	329A	Hose	2.0 meters	1
224	Special Spring Washer		10	330A	Hose	2.0 meters	1
225	Tension Shaft		1	331A	Hose	1.5 meters	1
229	Plate		1	332A	Manifold		1
230	Hex. Socket Cap Screw	M6x12	2	333A	Motor		1
230-1	Washer	M6	2	334A	Pump		1
231	Limit Switch		1	335A	Oil Gauge		1
232	Hex. Socket Cap Screw	M4x25	2	336A	Solenoid	2D2	1
239	Nut	M16	1	337A	Solenoid	3C2	1
240A	Slide Bracket		1	338A	Reducing		1
240A-1	Spring Washer	M10	3	339A	Oil Fill Port		1
240A-2	Hex. Socket Cap Screw	M10x45	3	340A	Tank Cover		1
240A-3	Set Screw	M10x25	1	341A	Tank		1
244	Cover Plate		1	P01	Control Panel		1
245	Hex. Socket Cap Screw	M6x8	2	P01-1	Main Board		1
246	Gib		2	P01-2	Display Board		1
247	Spring Washer	M8	6	P02	Electrical Box Cover		1
248	Hex. Socket Cap Screw	M8x20	6	P03	Electric Box Platform		1
249	Blade Guide Movable Rod		1	P04	Electric Parts Plate		1
249-1	Hex. Socket Cap Screw	M6x8	1	P04-1	Transformer		1
250	Set Screw	M6x12	4	P04-2	Fuse Block		3
251	Hex. Socket Cap Screw	M8x20	2	P04-3	Power in Fuse		3
252	Setting Bracket		1	P04-4	Grounding Plate		1
253	Hex. Socket Cap Screw	M12x50	1	P04-5	Input Fuse		2
254	Handle		1	P05	Electric Parts Plate (Rear)		1
256	Guide Bracket		1	P05-1	Dual Terminal Connector		1
257	Nozzle		1	P05-2	Connector PC Board		1
259	Bolt		2				

1000615

WE-270DSA

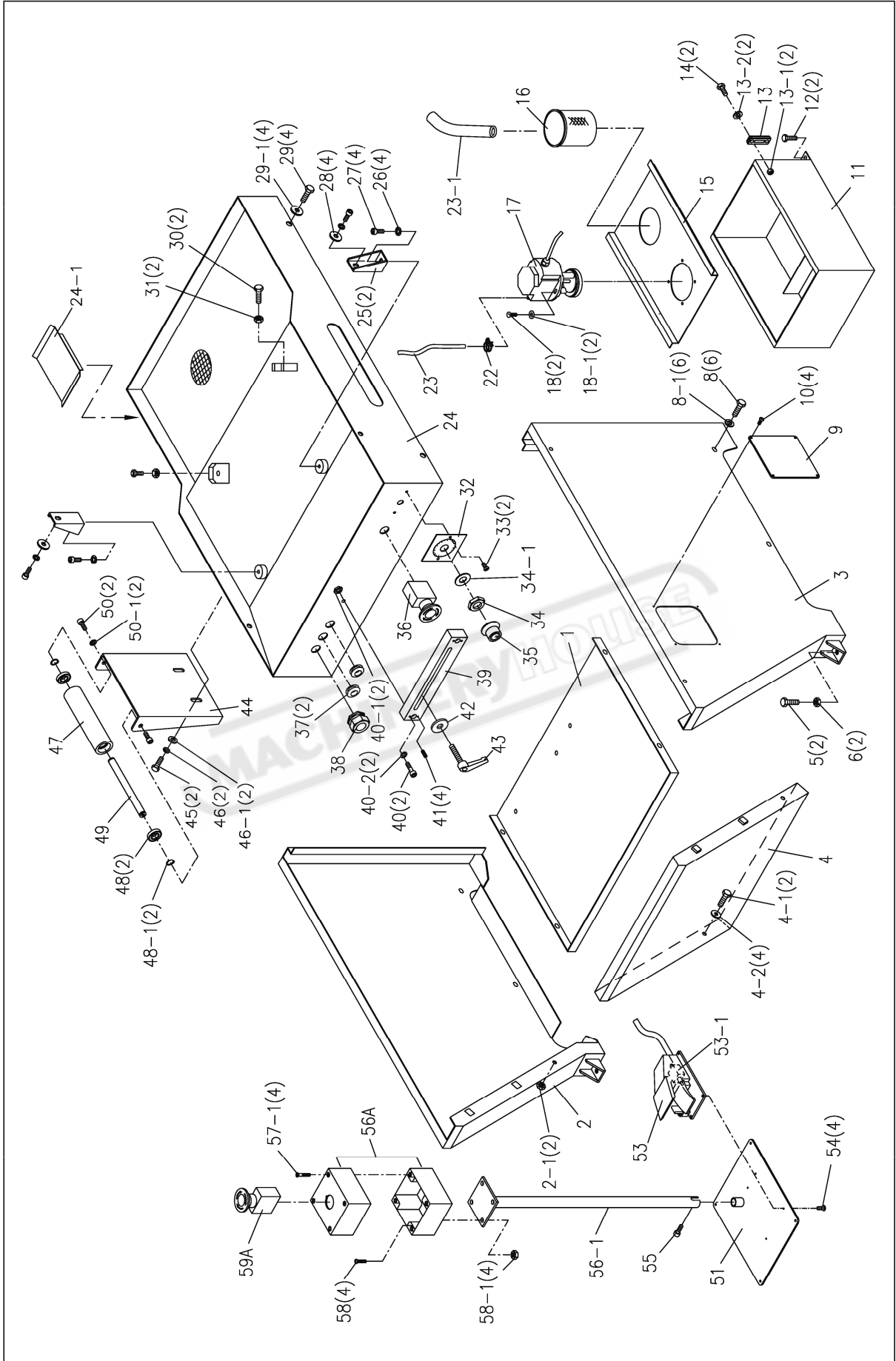

991201-V8

WE-270DSA

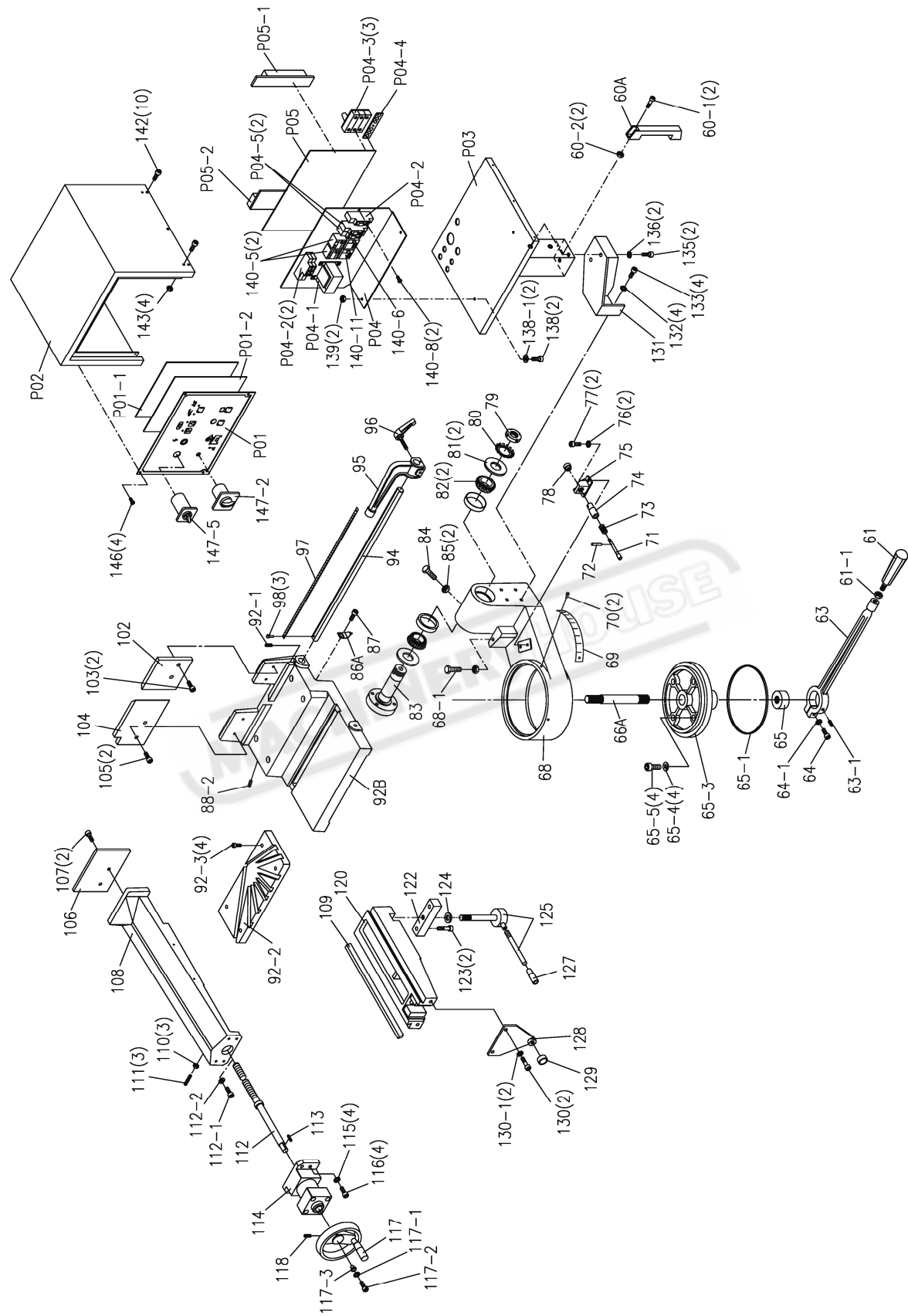

1000615-V6



WE-270DSA

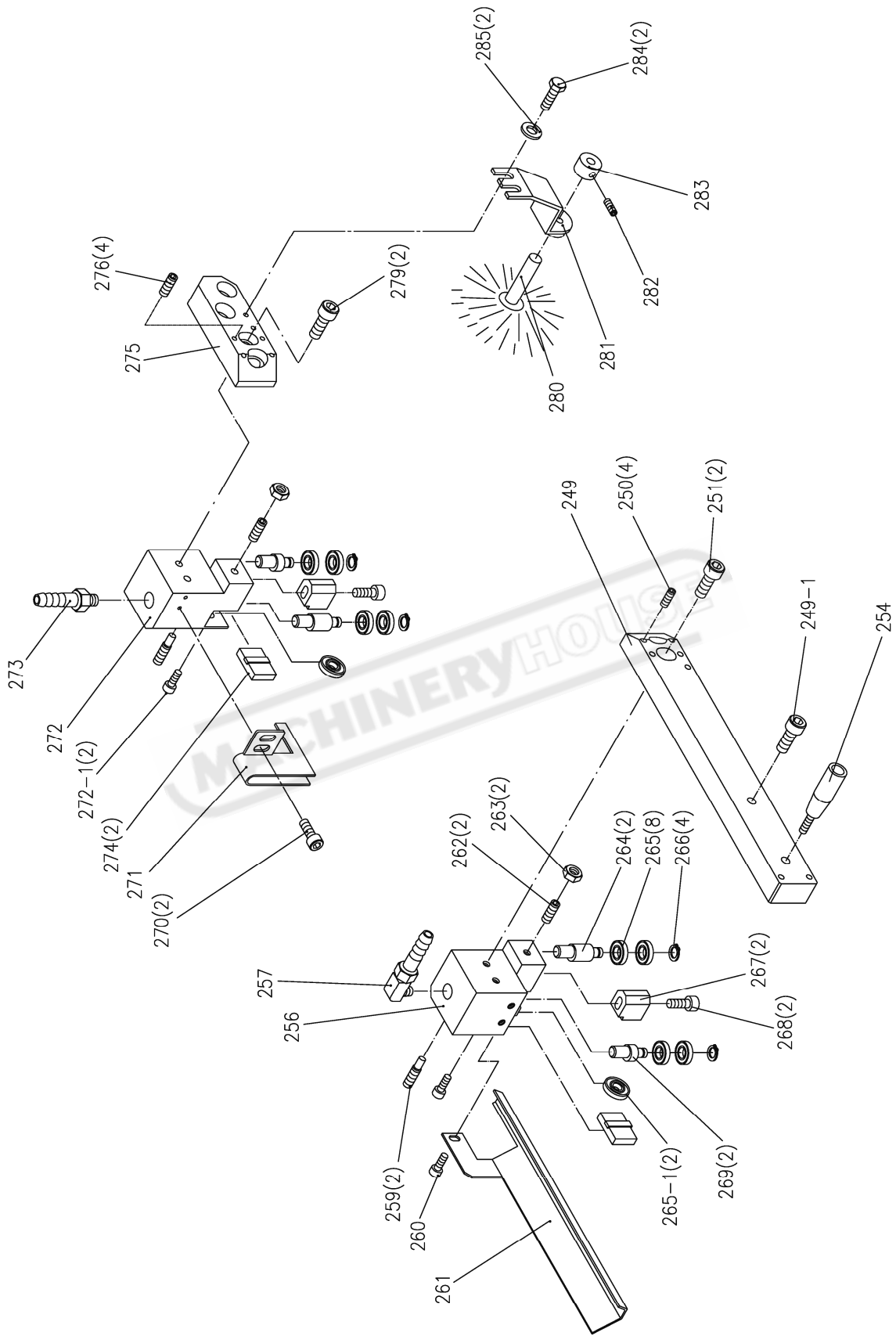

991201-V2

# Semi Auto and Vise Hydraulic System

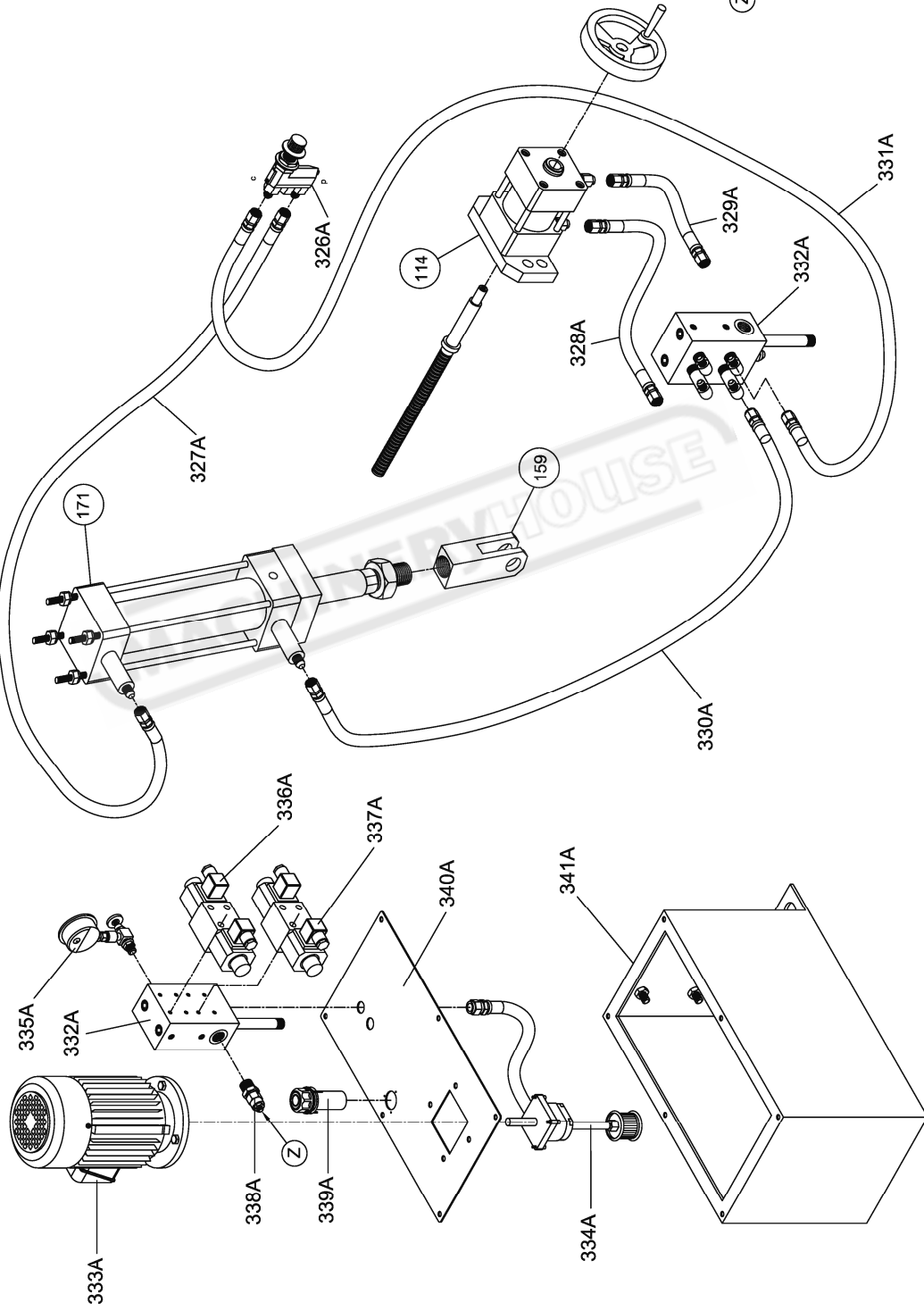

950605-V2

WE-270DSA